

Output Module LED Connections

For 32, 64, 96 or 128 Outputs / 0 Digit
Multiplexed Modules

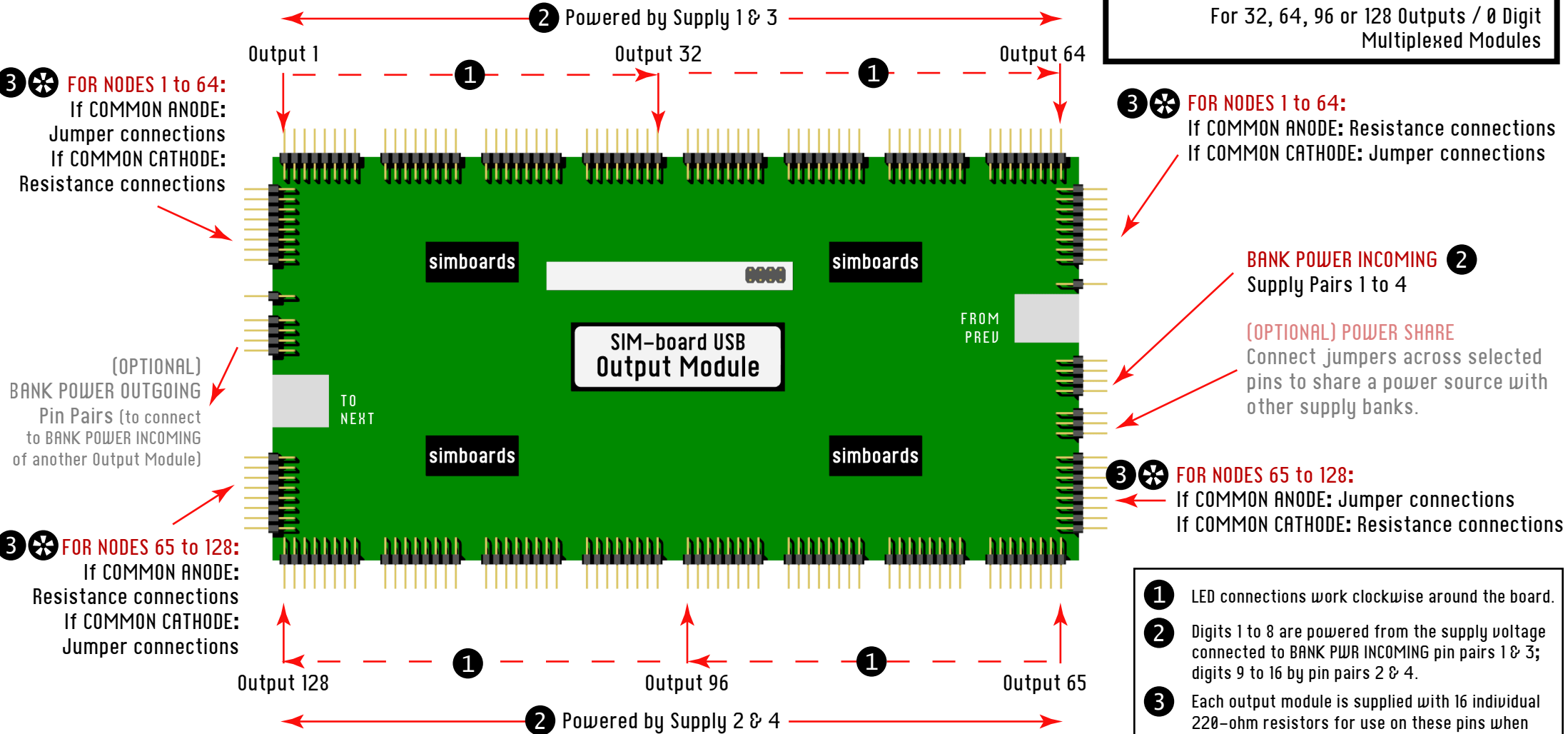

✳ **Default Module Status is COMMON ANODE.**
This is the **RECOMMENDED** polarity configuration to use when connecting LEDs to this module.
The polarity can be changed in the "Module Settings" area of the SIM-board Universal Controller software when viewing this module's nodes.