

Output Module Connecting Node Power Supplies

(OPTIONAL)
BANK POWER OUTGOING
Pin Pairs (to connect
to BANK POWER INCOMING
of another Output Module)

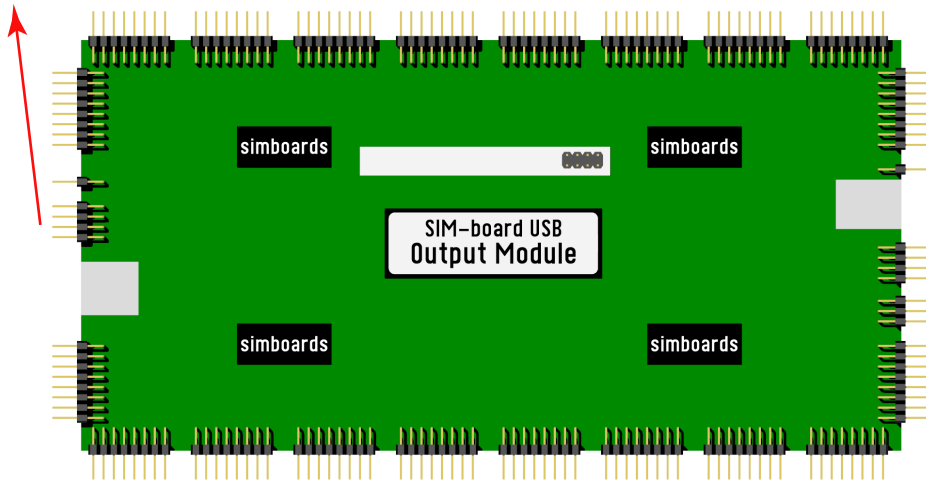

POWER NODE CONNECTIONS
Supplies A to D

POWER NODE OUT
Pin Pairs A to D

BANK POWER INCOMING
Supply Pairs 1 to 4

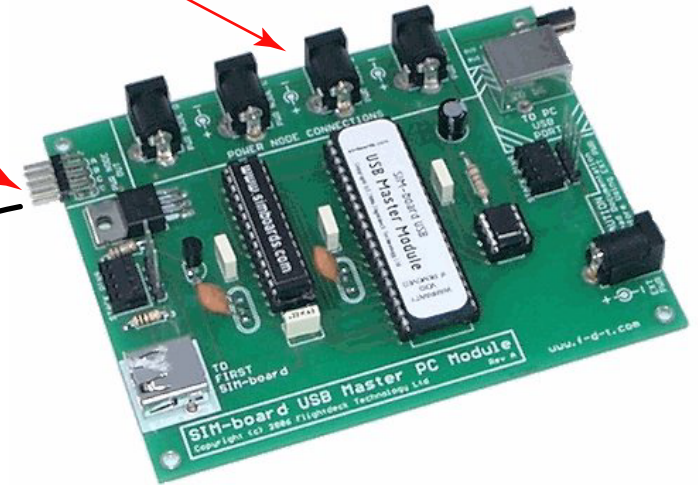

Each Output Module in your chain will require a source of DC power to drive the elements connected to it. You can use sources in the range 5V to 30V DC to drive the outputs of an Output Module.

Viewing the connection documents for the Output Module will show the locations of the 4 INCOMING and OUTGOING power supply connection pin pairs. The top-most pin is the POSITIVE (+) connection and the bottom-most pin is the NEGATIVE (-) connection, for each of the 4 pairs available.

A DC power source can be directly connected to the INCOMING pins via normal crimp contacts.

Alternatively, you can use your SIM-board Master Module's "POWER NODE CONNECTIONS" bank to keep up to 4 DC sources organized in one location. Simply plug in up to 4 separate DC sources (as required) to the DC sockets marked "POWER NODE A/B/C/D". Supplies must be of the center-positive 2.1mm barrel variety. The supply connected to each of these sockets is then made available to distribute from the equivalently labelled "POWER NODE OUT" pin pairs, from which you can run your power wiring to the BANK PWR INCOMING pins of your Output Modules that require it.

You can continue the power distribution from one Output Module to another Output Module that requires the same power source by using the BANK PWR OUTGOING pin pairs of the first Output Module, and connecting directly to the BANK PWR INCOMING pin pairs of the next module requiring the power source(s).